

Vaisala CARBOCAP® Carbon Dioxide Probe GMP343:

Diffusion-based Soil Respiration Chamber Measurements

This application note contains general information about soil respiration and discusses some issues worth considering while conducting measurements with soil respiration chambers. Some basic hints and guidelines on how to use a GMP343 in a soil-respiration chamber for CO₂ flux measurements in the surface-atmosphere boundary layer are also given. The primary mechanism for transport of CO₂ from the soil to the atmosphere is diffusion, thus measuring the CO₂ flux with the aid of a soil respiration chamber and an infrared-based CARBOCAP® diffusion sampling CO₂ probe eliminates complex pump sampling systems. Also a reference list of some scientific publications on chamber-based measurements of soil respiration is given.

Terrestrial carbon cycle

The flux of CO₂ emitted from the soil surface to the atmosphere is mainly originated from the respiration of roots as well as decomposition of root parts, soil organic matter and plant litter. It is also influenced by carbon binding of surface vegetation in photosynthesis as well as the cellular respiration of organisms. The CO₂ flux from soil is a good indicator of overall biological activity of the soil and is often used when studying the soil carbon cycle, see *Figure 1*.

Fluxes vary with soil and vegetation type, as well as season, time of day, and weather conditions. Carbon fluxes between the atmosphere and the biosphere are also highly sensitive to changes in the climate. Therefore, the carbon cycle needs to be monitored. Although soils form one of the largest reservoirs of carbon on earth, the exact potential of the biosphere as a carbon source or sink is uncertain. Also land use, such as soil tillage, may increase the CO₂ flux considerably.

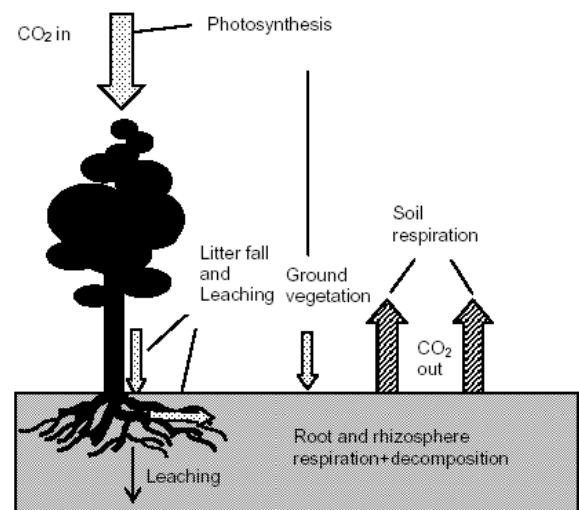

Figure 1. Carbon fluxes and factors controlling them in an ecosystem [7].

Soil-atmosphere chamber measurements

There are three general ways to study soil-atmosphere gas exchange rate:

- calculation from gas diffusion in the soil,
- micrometeorological techniques and
- chamber methods [1].

This application note describes chamber-based methods and especially the methods when using the Vaisala CARBOCAP® Carbon Dioxide Probe GMP343.

The chamber method is based on monitoring changes in CO₂ concentration inside a bottomless container placed on

the soil surface. The function of the chamber is to restrict the volume of the gas exchange so that any net emission or uptake of CO₂ can be measured as a concentration change. Soil respiration chambers can be only used to measure gas fluxes on the soil surface and not within the soil profile. For soil profile CO₂ measurements with the GMP343, see "*Below-Ground CO₂ measurements*" App. Note.

The use of infra-red based methods is becoming increasingly common and is widely accepted for chamber-based soil respiration measurements [2]. In addition, soil respiration chambers are relatively low in cost and simple to use. However, special care should be taken when constructing the chamber, since it is widely recognized that chamber-based measurements are subject to many potential errors such as disturbance of the boundary layer at the soil surface, pressure fluctuations and heating, etc.

Different chamber types

The three major types of chambers used for measuring soil gas fluxes are *non-steady state non-flow-through* (also called *closed static chamber*), *non-steady-state flow-through chamber* (also called *closed dynamic chamber*), and *steady-state flow-through chamber* (also called *open dynamic chamber*). In non-steady-state chambers, both the flow-through and non-flow-through types, the CO₂ efflux is determined from the change of gas concentration in a chamber, which has been placed on the soil surface for a known period of time. In steady-state chambers, the CO₂ efflux is calculated from the difference between the CO₂ concentration at the inlet and the outlet of the chamber. [3]

A detailed study on the comparison of different chamber techniques for measuring soil CO₂ efflux can be found from [3]. Since no single method has been established as a standard for soil-respiration chambers, the study concentrates on comparing different methods against a known CO₂ efflux. Discussion on different chamber techniques can also be found from [6].

The GMP343 is recommended to be used with a **non-steady state non-flow-through** (also called a closed static chamber), since the GMP343 can measure the concentration change in real-time (see the product specifications for the response time).

Chamber design

Most scientists make their own soil respiration chambers either from sheets of metal, glass or transparent plastic. A material that is nonpermeable, nonreactive, and not a sink or a source of CO₂ should be chosen. These materials include stainless steel, aluminium, acrylic plastic, polyvinyl chloride etc. [6]. However, when choosing a material for a transparent chamber, its optical properties also for ultraviolet transparency must also be considered.

The size of the box is essential since the area of resolution of the respiration measurement depends on the length and width of the chamber (or diameter in case of a circular chamber). Chamber geometry appears to have little direct effect on flux estimates as long as adequate air mixing is achieved inside the chamber. Larger chambers may be less accurate for measuring small CO₂ fluxes than smaller chambers. On the other hand, larger chambers are less sensitive to leaks, problems associated with humidity increases and errors in volume determination. However, chambers with small cross-section can be used in uneven terrain, whereas large chambers are difficult to match between rocks, vegetation and tree roots.

The speed of the CO₂ build-up can be adjusted by changing the chamber volume, the height must however be able to incorporate the ground vegetation. Generally a small chamber is fast while a large chamber is slower. However, different box sizes are needed because the CO₂ flux varies between different soil types - In some cases the CO₂ concentration increases from ambient only 20 ppm while sometimes one can reach concentrations as high as 700 to 800 ppm. It must be also noted, that the smaller the chamber is, the more significant will the effects of the fringe area of the chamber be.

It is essential for the measurement to seal the chamber properly against the ground. This is often done by making a collar for the chamber, where the bottom edge of the collar is sharpened to facilitate its insertion into soil (usually about 5 to 10 cm). The actual chamber is then placed on the collar. A closed cell foam gasket or water can provide a good seal between the chamber collar and the actual box. However, regardless of which type of chamber is used, its placement on the soil surface disturbs natural conditions and can change the flux it was intended to measure.

During the measurement the ambient temperature and pressure should, as much as is possible, be preserved within the chamber. When using the diffusion version of the GMP343, no pressure gradients are created, on the contrary to the case with a pump aspirated systems. However, mixing the air inside the chamber must be taken care of, but in a manner that soil surface is not disturbed with pressure fluctuations.

Factors influencing Chamber performance

The principle factors influencing chamber operation include soil and air temperature, CO₂ concentration gradients, pressure fluctuations, soil and air moisture, site disturbance, leakage, and air mixing method [6].

Temperature (soil and air):

Chambers must be deployed so that changes in near-surface soil temperature can be avoided. Temperature affects the transpiration as well as photosynthesis and respiration of ground vegetation due to possible changes in stomatal conductance. This means that the plant stomata reacts to rising temperatures (and humidity). The temperature should be monitored during the respiration measurement to identify potential impacts on soil respiration.

Humidity:

Chambers or their collars can modify soil moisture and thus the CO₂ flux by intercepting or excluding rainfall and run-off water. Soil respiration boxes should not be used during rainfall. Condensed water inside the soil respiration chamber can also shade the vegetation and thus affect photosynthesis.

Also when a chamber is placed on a moist soil surface, water vapour increases and displaces the chamber air, diluting the CO₂ concentration, so that the amount of CO₂ appears to be less than it really is. Largest errors will occur on wet soils on dry sunny days when chamber air temperature (and water vapour) will rise rapidly. **It is advisable to measure the humidity and the temperature inside the box in order to ensure that the conditions are not too extreme.** If the Vaisala MI70 indicator is used for the soil respiration measurement, an extra RH & T probe (for example the Vaisala HUMICAP[®] Humidity and Temperature Probe HMP75) can easily be connected to the indicator so that RH & T can be monitored and logged at the same time with the CO₂ measurement inside the respiration box.

Pressure fluctuations:

A properly designed venting tube transmits changes in external atmospheric pressure to the chamber headspace, and thus minimises suppression and the effect on the CO₂ flux. While using the GMP343 in short term measurements where ambient pressure does not significantly change, these pressure fluctuations can be neglected. However, placing the chamber on the soil must be done slowly and carefully in order to avoid pressure build-up. The first measurement results might have to be neglected if pressure fluctuations have had an effect on the measurement.

Mixing the air in the chamber:

The air in the chamber headspace must be sufficiently mixed in order to correctly sample the chamber CO₂ concentration. This is typically done with a small fan. The mixing of the air must be, however, done without ventilating the surface of the soil. The soil is porous and thus ventilating the soil surface might cause excess CO₂

flux from the soil to the surface. Care needs also to be taken that no local pressure gradients are developed while mixing the air in the chamber.

Measuring with the GMP343

The typical choice of chamber type when measuring with the Vaisala CARBOCAP® Carbon Dioxide Probe GMP343 is a non-flow-through chamber. Since the sampling method of the GMP343 is based on diffusion, the entire probe or only its measurement cell can be directly placed inside the chamber.

The measurement procedure starts by carefully ventilating the chamber. After closing the chamber gently, the CO₂ concentration starts to build up or decrease, depending on the conditions and the type of chamber, see *Figures 2 and 4*. In a dark respiration chamber, a rising CO₂ concentration will eventually reach equilibrium, gradually decreasing also the CO₂ flux from the soil. The CO₂ concentration should not be allowed to build up too high above the ambient CO₂ level. From the monitored CO₂ ramp, the CO₂ flux from soil can be calculated. However, it must be noted that the very first measurement results might have to be neglected, due to the effect of pressure fluctuations.

The response time of the GMP343 can be decreased by changing the numerical filtering (*see product specifications and user's guide for more details*). To further decrease the response time, the filter and filter cover can be removed.

The measurement result

If a closed opaque chamber (*Figure 2*) is placed on the soil, the rate of CO₂ concentration increase in the system should be linear (*Figure 3*). After a while saturation might occur, once the increased CO₂ concentration in the chamber starts affecting the flux from the ground.

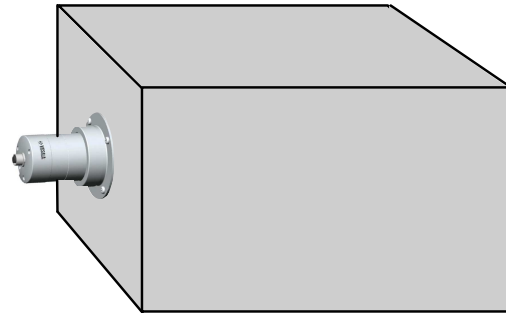

Figure 2. The GMP343 mounted in opaque soil-respiration chamber (dark respiration chamber)

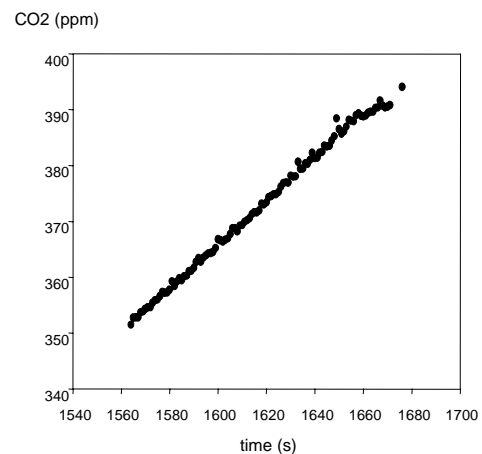

Figure 3. CO₂ concentration building up in dark respiration

While using a transparent soil-respiration chamber (*Figure 4*) during day time, the CO₂ concentration inside the chamber might be decreasing (*Figure 5*) due to possible photosynthesis of the vegetation inside the box.

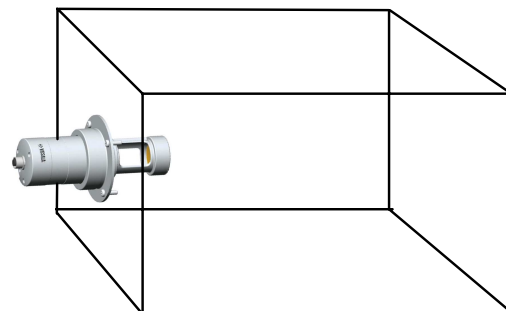

Figure 4. The GMP343 mounted in a transparent soil-respiration chamber (day time respiration chamber)

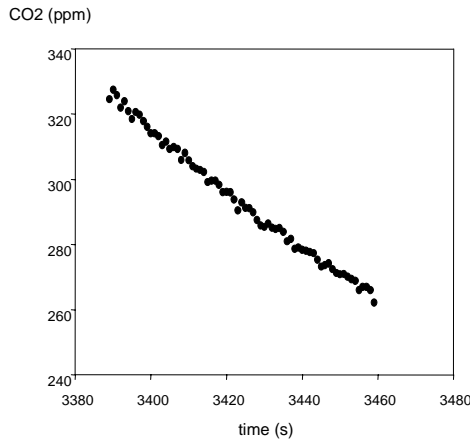

Figure 5. CO₂ concentration decreasing in day time respiration

From the measurements, the soil CO₂ efflux can be calculated with a mass balance equation for CO₂

$$Q = \frac{\Delta(V_C C_i)}{\Delta t},$$

where Q is the soil CO₂ efflux, V_C is the volume of the chamber C_i is the CO₂ concentration in the chamber. By a division of Q with the soil surface that the chamber covers, the CO₂ efflux per squaremeter can be calculated.

References:

[1] Hutchinson, G.L. and G.P. Livingston. 2002. *Soil - atmosphere gas exchange*. p. 1159-1182. In J.H. Dane and G.C. Tpp (ed.) *Methods of soil analysis. Part 4*. SSSA Book Ser. 5. SSSA. Madison, WI

[2] Davidson, E.A., K. Savage, L.V. Verchot, Rosa Navarro, *Minimizing artifacts and biases in chamber-based measurements of soil respiration*, *Agricultural and Forest Meteorology* 113 (2002) 21-37

[3] Pumpanen J., Kolari P., Ilvesniemi H., Minkkinen K., Vesala T., Niinistö S., Lohila A., Larmola T., Morero M., Pihlatie M., Janssens I., Curiel Yuste J., Grünzweig J. M., Reth S., Subke J.-A., Savage K., Kutsch W., Østreng G., Ziegler W., Anthoni P., Lindroth A. and Hari P. 2004. *Comparison of different chamber techniques for measuring soil CO₂ efflux*. *Agricultural and Forest Meteorology* 123: 159-176.

[4] Hutchinson G.L. and G.P. Livingston, *Vents and Seals in non-steady-state chambers used for measuring gas exchange between soil and the atmosphere*, *European Journal of Soil Science*, December 2001, 52, 675-682

[5] Hutchinson G.L., G.P. Livingston, R.W. Healy, and R.G. Striegl, *Chamber measurement of surface-atmosphere trace gas exchange: Numerical evaluation of dependence on soil, interfacial layer and source/sink properties*, *Journal of Geophysical Research*, Vol. 105, No. D7, Pages 8865-8875, April 16, 2000

[6] Rochette P. and G.L. Hutchinson. *Measurement of Soil Respiration in situ: Chamber techniques*. A hardcopy available.

[7] Pumpanen, J. *CO₂ efflux from boreal forest soil before and after clear-cutting and site preparation*, University of Helsinki Department of Forest Ecology Publications 30