

HMT300TMK Turbine Mounting Kit for Power Turbine Intake Air Measurement



The Vaisala HUMICAP® Turbine Mounting Kit HMT300TMK is shown with the cover open.

The Vaisala HUMICAP® Turbine Mounting Kit HMT300TMK is developed to monitor the air intake of gas and liquid fueled power turbines.

It is ideal for measuring in water vapor injection applications because the sensor has been optimized for high humidity environments by utilizing a patented, warmed probe.

Water vapor is added to the intake of the turbine to increase the mass flow which in turn increases compression and electrical power output.

Low maintenance

Power turbines also require exact water vapor injection in the chamber to reduce pollutant emissions. Vaisala's warmed probe technology is ideal because of its reliability in the field. In fact, the only suggested scheduled maintenance is annual calibration.

Patented, warmed probe prevents condensation

The HMT300TMK with the HMT337

installed, provides fast and reliable dewpoint measurement especially under high humidity conditions where dew would normally form on the humidity sensor and thereby cause errors in measurement. The patented warmed probe prevents condensation from forming on the sensor.

Protective enclosure

The HMT300TMK includes a white, painted aluminum enclosure with an installation kit for the probe. The HMT337 Humidity and Temperature Transmitter is installed in the aluminum enclosure at the factory. The instrument can be equipped to be powered with either 24 VDC/VAC or with an internal 110/230 volt power supply unit.

The outer cover protects the transmitter from direct sun light and rain. The installation kit protects the probe from outer water splashes, keeps the sensor dry, and prevents any parts that could vibrate loose from entering

Features/Benefits

- Designed for high humidity applications
- Measurement range: -40...+100°C
- Patented, warmed probe
- Incorporates Vaisala HUMICAP® Sensor for excellent accuracy and long-term stability and resistance to dust and most chemicals
- Low maintenance need
- Outer cover provides protection from rain and direct sunlight
- NIST traceable (certificate included)

the turbine.

The HMT300TMK can be ordered separately for installation with the customer's existing HMT337.

HUMICAP® performance

The HMT330 Series Transmitters are fitted with the latest generation of the HUMICAP®, the polymer sensor known for its accuracy, reliability and long-term stability. The sensor has a high tolerance for particulate abrasion and chemical contamination.

Vaisala HUMICAP® Humidity and Temperature Transmitter HMT337

The HMT337 is intended for demanding industrial humidity measurement applications with a risk of condensation. The stainless steel probe is mechanically durable and preferred for most industrial applications.



Technical Data

Dewpoint temperature

Measurement range -40...+100 °C (-40...+212 °F)
 Accuracy: find the intersection of the dewpoint temperature curve and the dewpoint difference reading (process temperature - dewpoint temperature) on the x-axis and read the accuracy in dewpoint measurement at the y-axis

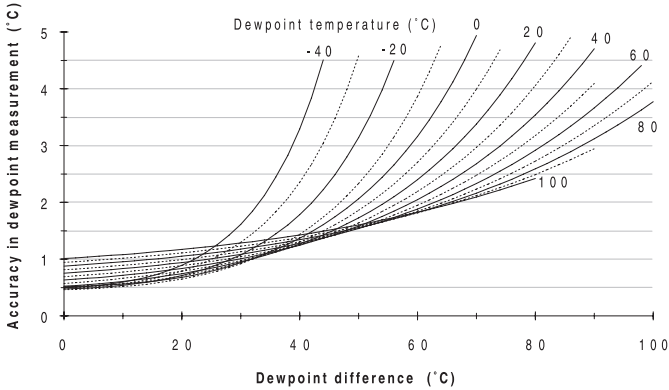

Response time (90%) at +20 °C (68 °F) in still air (PPS grid with steel netting) 20 s
 Sensor HUMICAP® 180C

Dimensions

Dimensions in mm (inches)

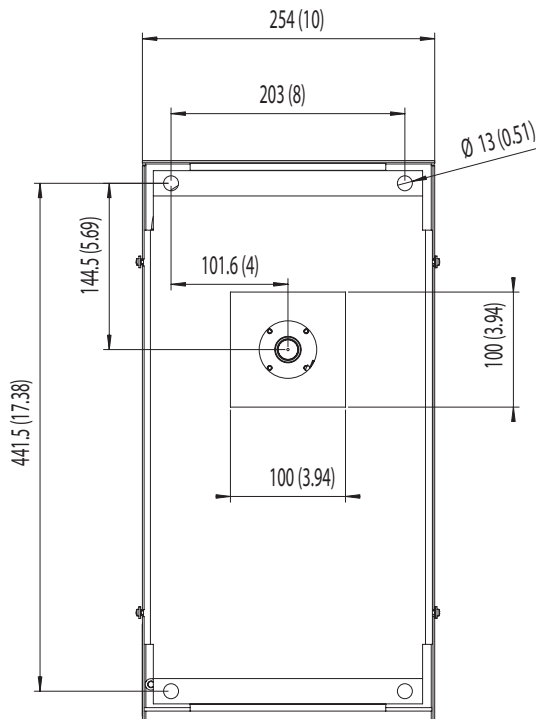

Outputs

Two standard outputs, third optional 0...20 mA, 4...20 mA, 0...1 V, 0...5 V, 0...10 V
 Typical accuracy of analog output at +20 °C (+68 °F) ±0.05 % full scale
 Typical temperature dependence of analog output ±0.005 %/°C full scale
 Serial output available RS232C (optional RS485)

General

Connections screw terminals for 0.5 mm² wires (AWG 20), stranded wires recommended
 Operating voltage 24 VDC/VAC (20...28 V) or 115/230 VAC (Must be specified at time of order)

Recommended external load for current outputs < 500 ohm
 0...1 V output > 2 kohm (to ground)
 0...5 & 0...10 V outputs > 10 kohm (to ground)
 Operating temperature range for electronics -40...+60 °C (-40...+140 °F)
 Storage temperature -55...+80 °C (-67...+176 °F)
 Housing material G-AlSi10 (DIN 1725)
 Housing classification IP65 (NEMA 4)
 Bushing 8...11 mm diameter cables (0.31...0.43 inch)
 Humidity sensor protection PPS grid with steel netting (Ø 12 mm)
 Electromagnetic compatibility Complies with EMC standard EN61326-1, Industrial Environment

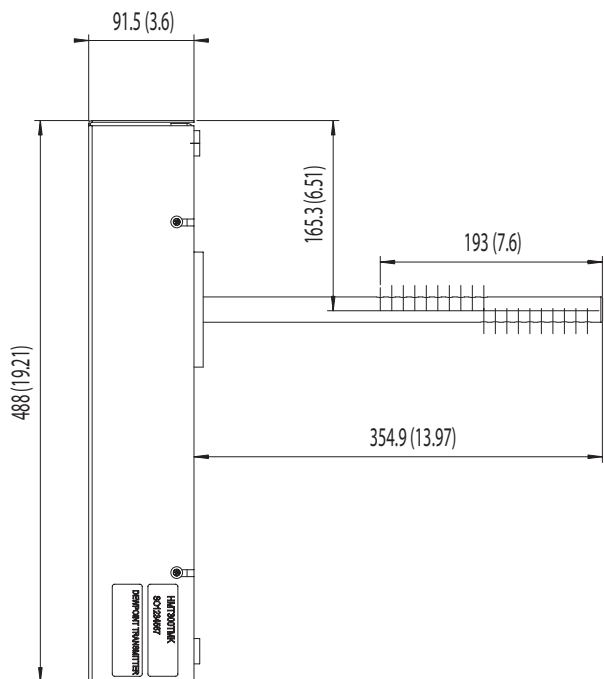

HUMICAP® is a registered trademark of Vaisala.
 Specifications subject to change without prior notice.
 ©Vaisala Oyj

